

Sr.No. **25218**

**E**

**2015 (I)  
ENGINEERING SCIENCES  
TEST BOOKLET**

SUBJECT CODE BOOKLET CODE

**6**

**C**

Time : 3:00 Hours

Maximum Marks: 200

**INSTRUCTIONS**

1. This Test Booklet contains one hundred and fifteen (20 Part 'A'+25 Part 'B' + 70 Part 'C') Multiple Choice Questions (MCQs). You are required to answer a maximum of 15, 20 and 20 questions from part 'A' 'B' and 'C' respectively. If more than required number of questions are answered, only first 15, 20, 20 questions in Parts 'A' 'B' and 'C' respectively, will be taken up for evaluation.
2. **OMR** answer sheet has been provided separately. Before you start filling up your particulars, please ensure that the booklet contains requisite number of pages and that these are not torn or mutilated. If it is so, you may request the Invigilator to change the booklet of the same code. Likewise, check the OMR answer sheet also. Sheets for rough work have been appended to the test booklet.
3. Write your Roll No., Name and Serial Number of this Test Booklet on the OMR answer sheet in the space provided. Also put your signatures in the space earmarked.
4. **You must darken the appropriate circles with a black ball pen related to Roll Number, Subject Code, Booklet Code and Centre Code on the OMR answer sheet. It is the sole responsibility of the candidate to meticulously follow the instructions given on the Answer Sheet, failing which, the computer shall not be able to decipher the correct details which may ultimately result in loss, including rejection of the OMR answer sheet.**
5. Each question in Part 'A' carries 2 marks, Part 'B' 3.5 marks and Part 'C' 5 marks respectively. There will be negative marking @ 25% for each wrong answer.
6. Below each question in Part 'A', 'B' and 'C' four alternatives or responses are given. Only one of these alternatives is the "correct" option to the question. You have to find, for each question, the correct or the best answer.
7. Candidates found copying or resorting to any unfair means are liable to be disqualified from this and future examinations.
8. Candidate should not write anything anywhere except on answer sheet or sheets for rough work.
9. Use of scientific calculator without data connectivity is permitted.
10. **After the test is over, at the perforation point, tear the OMR answer sheet, hand over the original OMR answer sheet to the invigilator and retain the carbonless copy for your record.**
11. Candidates who sit for the entire duration of the exam will only be permitted to carry their Test booklet.

Roll No.....

Name .....

OMR Answer Sheet No.....

S/15 CRS/15—6CE—1A

I have verified all the information filled in by the candidate.

.....  
Signature of the Invigilator

FOR ROUGH WORK

---

## PART 'A'

1. By reading the accompanying graph, determine the INCORRECT statement out of the following.

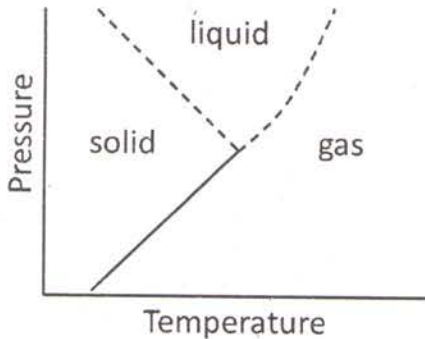









1. Melting point increases with pressure
  2. Melting point decreases with pressure
  3. Boiling point increases with pressure
  4. Solid, liquid and gas can co-exist at the same pressure and temperature
2. A float is drifting in a river, 10 m downstream of a boat that can be rowed at a speed of 10 m/minute in still water. If the boat is rowed downstream, the time taken to catch up with the float
1. will be 1 minute
  2. will be more than 1 min
  3. will be less than 1 min
  4. can be determined only if the speed of the river is known
3. Consider a series of letters placed in the following way:

U \_ G \_ C \_ C \_ S \_ I \_ R

Each letter moves one step to its right and the extreme right letter takes the first position, completing one operation.

After which of the following numbers of operations do the Cs not sit side by side?

- |       |       |
|-------|-------|
| 1. 3  | 2. 10 |
| 3. 19 | 4. 25 |
4. If you change only one observation from a set of 10 observations, which of the following will definitely change?
1. Mean
  2. Median
  3. Mode
  4. Standard deviation
5. An inclined plane rests against a horizontal cylinder of radius  $R$ . If the plane makes an angle of  $30^\circ$  with the ground, the point of contact of the plane with the cylinder is at a height of
- |              |              |
|--------------|--------------|
| 1. $1.500 R$ | 2. $1.866 R$ |
| 3. $1.414 R$ | 4. $1.000 R$ |
6. In a fast moving car with open windows, the driver feels a continuous incoming breeze. The pressure inside the car, however, does not keep increasing because,
1. air coming in from the front window goes out from the rear.
  2. air comes in as well as goes out through every window but the driver only feels the incoming one.
  3. no air actually comes in and the feeling of breeze is an illusion.
  4. cool air reduces the temperature therefore the pressure does not increase.
7. What is the maximum number of parallel, non-overlapping cricket pitches (length 24 m, width 3 m) that can be laid in a field of diameter 140 m, if the boundary is required to be at least 60 m from the centre of any pitch?
- |       |      |
|-------|------|
| 1. 6  | 2. 7 |
| 3. 12 | 4. 4 |

8. The product of the perimeter of a triangle, the radius of its in-circle, and a number gives the area of the triangle. The number is
1.  $1/4$
  2.  $1/3$
  3.  $1/2$
  4. 1
9. The maximum number of points formed by intersection of all pairs of diagonals of convex octagon is
1. 70
  2. 400
  3. 120
  4. 190
10. Each of the following pairs of words hides a number, based on which you can arrange them in ascending order. Pick the correct answer:
- I. Cloth reel
  - J. Silent wonder
  - K. Good tone
  - L. Bronze rod
1. L, K, J, I
  2. I, J, K, L
  3. K, L, J, I
  4. K, J, I, L
11. Which of the following values is same as  $2^{2^{2^2}}$ ?
1.  $2^6$
  2.  $2^8$
  3.  $2^{16}$
  4.  $2^{222}$
12. If
- $$\begin{array}{r} 2a \\ \times b2 \\ \hline c6 \\ 84 \\ \hline 8d6 \end{array}$$
- Here a, b, c and d are digits.  
Then  $a + b =$
1. 4
  2. 9
  3. 11
  4. 16
13. A  $12\text{ m} \times 4\text{ m}$  rectangular roof is resting on four 4 m tall thin poles. Sunlight falls on the roof at an angle of  $45^\circ$  from the east, creating a shadow on the ground. What will be the area of the shadow?
1.  $24\text{ m}^2$
  2.  $36\text{ m}^2$
  3.  $48\text{ m}^2$
  4.  $60\text{ m}^2$
14. Find the height of a box of base area  $24\text{ cm} \times 48\text{ cm}$ , in which the longest stick that can be kept is 56 cm long.
1. 8 cm
  2. 32 cm
  3. 37.5 cm
  4. 16 cm
15. An infinite row of boxes is arranged. Each box has half the volume of the previous box. If the largest box has a volume of 20 cc, what is the total volume of all the boxes'?
1. Infinite
  2. 400 cc
  3. 40 cc
  4. 80 cc
16. Find the missing element based on the given pattern
- A.  B.  C. 
- A.  B.  C. ?
1. 
  2. 
  3. 
  4. 
17. A man starts his journey at 0100 Hrs local time to reach another country at 0900 Hrs local time on the same date. He starts a return journey on the same night at 2100 Hrs local time to his original place, taking the same time to travel back. If the time zone of his country of visit lags by 10 hours, the duration for which the man was away from his place is



25. Let  $A = \begin{pmatrix} 1 & 2 & -3 & 4 \\ 2 & 5 & -2 & 1 \\ 5 & 12 & -7 & 6 \end{pmatrix}$ . Consider

the system of equations  $A \begin{pmatrix} x \\ y \\ z \\ t \end{pmatrix} = \begin{pmatrix} 2 \\ 1 \\ 7 \end{pmatrix}$ .

Then the rank of  $A$  is

1. 3 and the above system has a solution
2. 3 and the above system has NO solution
3. 2 and the above system has a solution
4. 2 and the above system has NO solution

26. Let  $f(x, y) = y^2 + 2x^2y$  for all  $(x, y) \in \mathbb{R}^2$ . Then  $f$  has a local minimum

1. at  $(0, 0)$  but NOT at  $(1, 0)$
2. at  $(1, 0)$  but NOT at  $(0, 0)$
3. at both  $(0, 0)$  and  $(1, 0)$
4. neither at  $(0, 0)$  nor at  $(1, 0)$

27. Let  $A = \begin{pmatrix} 3 & 0 & 0 \\ 0 & 2 & -5 \\ 0 & \alpha & -2 \end{pmatrix}$  for some  $\alpha \in \mathbb{R}$ .

Suppose there exists a  $3 \times 3$  matrix  $P$  such that

$$P^{-1}AP = \begin{pmatrix} 3 & 0 & 0 \\ 0 & 3 & 0 \\ 0 & 0 & -3 \end{pmatrix}. \text{ Then the value}$$

of  $\alpha$  is

1. -1
2. 0
3. 1
4. 3

28. Consider the following improper integrals

$$I_1 = \int_1^\infty \frac{e^t}{t^2} dt \text{ and } I_2 = \int_1^\infty \frac{e^{-t}}{t} dt.$$

Then

1.  $I_1$  converges but NOT  $I_2$
2.  $I_2$  converges but NOT  $I_1$
3. both  $I_1$  and  $I_2$  converge
4. neither  $I_1$  nor  $I_2$  converges

29. Let  $\Gamma$  be a circle centred at zero on  $\mathbb{C} \setminus \{0\}$ . The value of

$$\int_{\Gamma} \left( \sin \frac{1}{z} + \sin^2 \frac{1}{z} \right) dz \text{ is equal to}$$

1. 0
2.  $\pi i$
3.  $2\pi i$
4.  $4\pi i$

30. Consider the initial value problem  $y'' + 4y' + 4y = 0$  with the initial conditions  $y(0) = 1$  and  $y'(0) = -1$ .

The value of  $\frac{y(\ln 2)}{1 + \ln 2}$  is

1.  $\frac{1}{4}$
2. 4
3.  $e^{-4}$
4. 1

### ENGINEERING APTITUDE

31. The Miller indices of the plane OLMN shown in the adjacent figure is

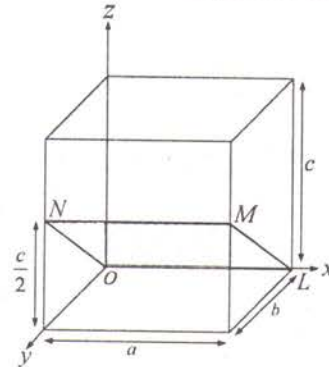

1.  $(0 \ 1 \ 2)$
2.  $(0 \ 1 \ \bar{2})$
3.  $(0 \ \bar{1} \ 2)$
4.  $(0 \ 2 \ \bar{1})$

32. The energy gap of GaAs is  $E_g = 1.42$  eV and experimental values for the effective densities of states at the bottom of conduction band ( $E_C$ ) and the top of valance band ( $E_V$ ), at room temperature, respectively, are  $N_C = 4.7 \times 10^{17} \text{ cm}^{-3}$  and  $N_V = 4.7 \times 10^{18} \text{ cm}^{-3}$ . The thermal voltage at room temperature is

$V_T = \frac{kT}{q} = 26 \text{ mV}$ . Concerning the position of Fermi level ( $E_F$ ) of intrinsic

GaAs at room temperature, which one of the following statements is true?

1.  $E_F - E_V = 0.710 \text{ eV}$
2.  $E_C - E_F = 0.675 \text{ eV}$
3.  $E_F - E_V = 0.675 \text{ eV}$
4.  $E_C - E_F = 0.745 \text{ eV}$

33. A positive point charge  $Q$  is located at a distance  $d$  from the centre of a grounded conducting sphere of radius  $a$  as shown in the figure. The force on  $Q$  caused by the charges induced on the sphere is

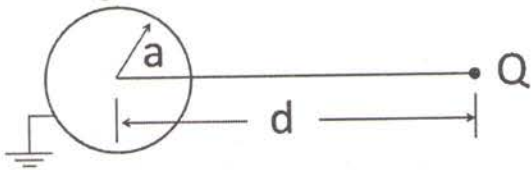

1. 0
2.  $\frac{Q^2}{4\pi\epsilon_0} \frac{a}{(d^2 - a^2)^{3/2}}$  towards the sphere
3.  $\frac{Q^2}{4\pi\epsilon_0} \frac{ad}{(d^2 - a^2)^2}$  towards the sphere
4.  $\frac{Q^2}{4\pi\epsilon_0} \frac{ad^2}{(d^2 - a^2)^2}$  towards the sphere

34. For the system shown, what is the natural frequency for small amplitudes of oscillations? The rod is uniform and has mass  $m$ .

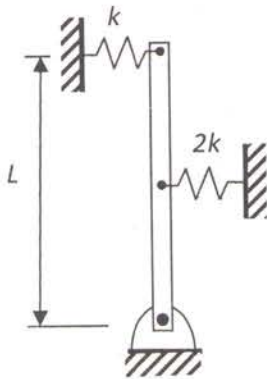

$$1. \sqrt{\frac{9k}{2m} - \frac{3g}{2L}} \quad 2. \sqrt{\frac{9k}{2m} + \frac{3g}{2L}}$$

$$3. \sqrt{\frac{3g}{2L} - \frac{9k}{2m}} \quad 4. 2\sqrt{\frac{9k}{2m} - \frac{3g}{2L}}$$

35. Consider the velocity field  $\vec{V} = Ax\hat{i} - Ay\hat{j}$ , where  $A = 0.1 \text{ s}^{-1}$  and the coordinates are measured in meters. A square element is marked in the fluid at initial time. With the evolution of time, the square element will become

1. Rectangle with x-dimension greater than y-dimension.
2. Parallelogram with non-orthogonal edges.
3. Rectangle with x-dimension less than y-dimension.
4. Rectangular hyperbola.

36. Considering the case of both the blocks shown slide together on the surface  $C$ , find the smallest value of the weight  $D$  that will cause the loss of static friction. Assume the coefficient of static friction between block  $A$  and  $B$  is 0.6 and the block  $B$  and the surface  $C$  as 0.4. Assume that block  $B$  does not slide over surface  $C$ .

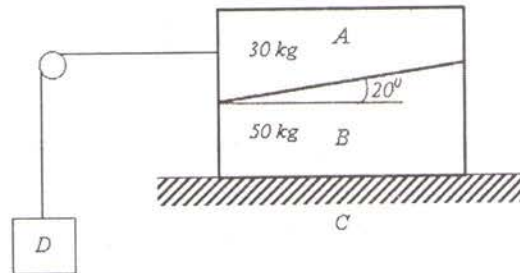

1. 26.2kg
2. 7.2kg
3. 5.8kg
4. 18kg

37. The standing wave ratio on a lossless  $50 \Omega$  transmission line terminated in an unknown load impedance is found to be 4. The distance between successive voltage minima is 25 cm and the first minima is located 10 cm from the load. The load impedance is
1.  $13.74 + j 15.15$
  2.  $18.48 + j 33.01$
  3.  $32.29 + j 57.66$
  4.  $82.13 + j 90.58$

38. Following statements are made for an ideal Otto cycle

- (a) All the processes are internally reversible.
- (b) Efficiency increases with the maximum temperature.
- (c) Efficiency does not depend on the type of gas executing the cycle
- (d) The gas temperature becomes maximum after compression.

1. (a) and (b) are true
2. (a) and (c) are true
3. (a) and (d) are true
4. (c) and (d) are true

39. A Carnot engine operates between two reservoirs at  $500^\circ\text{C}$  and  $100^\circ\text{C}$ , respectively. It rejects 250 kJ/cycle. The work developed/cycle is

1. 268 kJ
2. 518 kJ
3. 1000 kJ
4. 1250 kJ

40. Water is sprayed in air with a relative humidity of 50% in an adiabatic constant pressure process. Indicate the correct statement.

1. Dry bulb temperature decreases but wet bulb temperature increases.
2. Dry bulb temperature decreases but wet bulb temperature remains constant.

3. Dry bulb temperature decreases but relative humidity remains constant.
4. Both dry bulb temperature and dew point temperature decreases.

41. For the oscillator circuit shown, the OPAMP supply voltage is  $\pm 20 \text{ V}$ ,  $R = 400 \text{ k}\Omega$  and  $C = 100 \text{ pF}$ . The zener diode has a breakdown voltage of 6.8 V and a forward voltage drop of 0.7 V. The frequency and amplitude of output voltage ( $v_o$ ) are

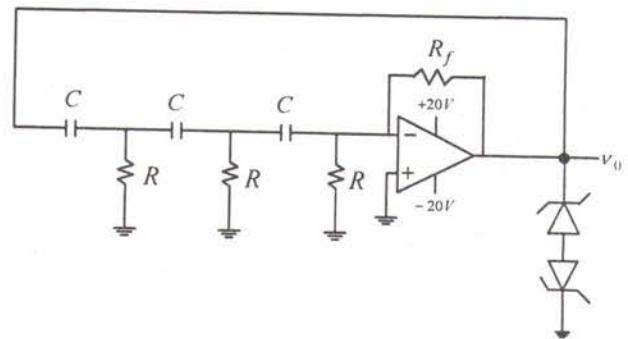

1. 1.625 kHz and 7.5 V
2. 3.980 kHz and 13.6 V
3. 10.210 kHz and 7.5 V
4. 25 kHz and 13.6 V

42. Match the following

- |  |                          |
|--|--------------------------|
| (a) Stress – ‘inverse square root of crack length’ | (i) Basquin equation     |
| (b) S-N curve                                      | (ii) Paris equation      |
| (c) Crack growth rate curve                        | (iii) Griffith equation  |
| (d) Stress – ‘inverse square root of grain size’   | (iv) Hall-petch equation |

1. (a) – (i), (b) – (ii), (c) – (iii), (d) – (iv)
2. (b) – (i), (c) – (ii), (d) – (iv), (a) – (iii)



3. (c) – (i), (d) – (ii), (a) – (iii), (b) – (iv)  
 4. (d) – (iv), (a) – (i), (b) – (iii), (c) – (ii)

43. In a linear and isotropic medium, the current density  $J$  is proportional to  $2\hat{i} - 3\hat{j} + \hat{k}$ . The magnetic flux density  $B$  is given by  $(x + C_1 z)\hat{i} + (x - 3z)\hat{j} + (x + C_2 y + C_3 z)\hat{k}$ , where  $C_1, C_2, C_3$  are constants. Assuming no time varying electric fields, the value of these constants are

1.  $C_1 = 1 \quad C_2 = 1 \quad C_3 = -0$
2.  $C_1 = -2 \quad C_2 = -1 \quad C_3 = -1$
3.  $C_1 = 4 \quad C_2 = 5 \quad C_3 = -1$
4.  $C_1 = 1 \quad C_2 = 1 \quad C_3 = -1$

44. A simply supported beam is loaded as shown in the figure. Find the magnitude of bending moment (BM) and shear force (SF) at the mid-span.

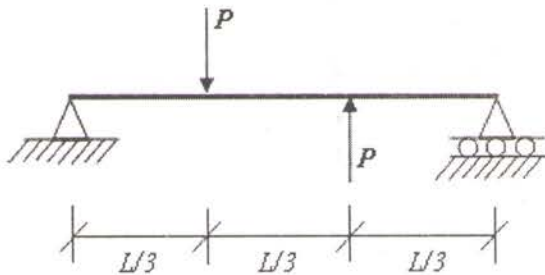

1.  $BM = \frac{PL}{12}; SF = \frac{P}{2}$
2.  $BM = \frac{PL}{12}; SF = \frac{2P}{3}$
3.  $BM = 0; SF = \frac{2P}{3}$
4.  $BM = 0; SF = \frac{P}{3}$

45. A turbulent flow is highly random and chaotic. Description for a typical turbulent velocity signal refers to one of the following true statements.

1. The turbulent velocity signal is deterministic and repeatable.
2. The mean and variance of the turbulent velocity signal is deterministic and is repeatable.
3. The turbulent flow is purely sinusoidal.
4. The turbulent velocity signal is statistically non-deterministic.

## PART 'C'

### COMPUTER SCIENCE

46. The cyclomatic complexity for a connected flow graph, with 11 flow graph edges and 8 flow graph nodes is:

1. 3
2. 5
3. 88
4. 19

47. The following is a set of processes that arrive at time 0 (with the given CPU burst time):  
 $P_1 : 5 \text{ ms}$ ,  $P_2 : 9 \text{ ms}$ ,  $P_3 : 7 \text{ ms}$ . Assume that the order in which these processes are processed is  $(P_1, P_2, P_3)$ .  
 The average waiting time of the processes if Round – Robin scheduling mechanism is used with a time quantum of 4 ms, assuming the order of processes to be  $(P_1, P_2, P_3)$  is:
1. 11 ms
  2. 10 ms
  3. 21 ms
  4.  $21/3 \text{ ms}$
48. The number of digits in the binary equivalent of  $(10000000000)_3$  is:
1.  $\lfloor 9 \log_2(3) \rfloor + 1$
  2.  $\lfloor 10 \log_2(3) \rfloor + 1$
  3.  $\lceil 10 \log_2(3) \rceil + 1$
  4.  $\lfloor 9 \log_3(2) \rfloor + 1$
49. Assume that the symbols  $\wedge, \vee, \neg$ , and  $\rightarrow$  denote logical AND, OR, NOT and implication respectively. The logical expression  $\neg((p \vee q) \rightarrow r)$  is logically equivalent to
1.  $(q \wedge r) \rightarrow \neg r$
  2.  $(p \wedge q) \wedge \neg r$
  3.  $(p \vee q) \wedge \neg r$
  4.  $(q \vee p) \rightarrow \neg r$
50. A question paper consists of 10 questions with 5 questions in Part A and 5 questions in Part B. A student must answer 7 out of these 10 questions with at least 3 selected from Part A. The number of ways in which the student can complete the examination is:
1. 70
  2.  $\binom{10}{7} = 120$
  3. 105
  4. 110
51. SDRAM cells are arranged in 8 K rows and it takes 4 clock cycles to read each row. At a clock rate of 1.33 GHz, the refresh overhead in each 64-ms time interval is:
1. 0.038
  2. 0.0038
  3. 0.00038
  4. 0.000038
52. What is printed by the following program?
- ```
#include <stdio. h>
void check( );
int a = 5 ;
int main()
{
    a+ = 4;
    check( );
    return 0 ;
}
void check( )
{
    ++ a ;
    printf ( " a = %d ", a );
}
```
1. a = 5
  2. a = 9
  3. a = 6
  4. a = 10

53. A node of a rooted binary tree is said to have preorder number  $i$ , if the node occurs in the  $i^{\text{th}}$  position in the preorder traversal sequence. The notions of postorder number and inorder number are defined in a similar manner. We use the notations  $PRE(X)$ ,  $POST(X)$  and  $IN(X)$  to denote the preorder number, postorder number and Inorder number of a node  $X$  respectively. Consider the following tree:

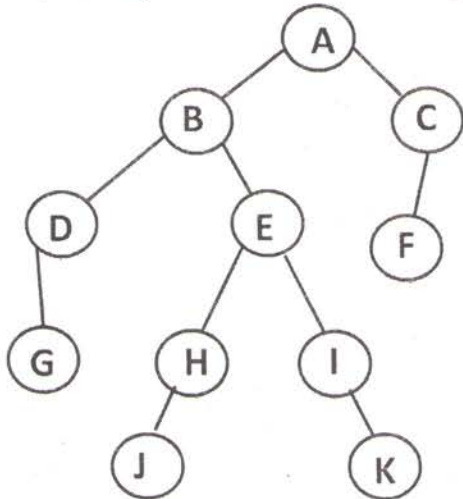

For the tree given above, which of the following is TRUE.

1.  $(PRE(A), POST(H), IN(F)) = (1, 4, 9)$
2.  $(PRE(B), POST(I), IN(D)) = (2, 6, 1)$
3.  $(PRE(C), POST(D), IN(E)) = (10, 3, 6)$
4.  $(PRE(J), POST(K), IN(G)) = (7, 5, 3)$

54. The cost of minimum cost spanning tree of the following graph is:

1. 72
2. 73
3. 74
4. 75

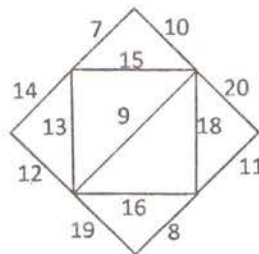

55. Let  $R = (A,B,C)$  & let  $r_1$  &  $r_2$  both be relations on schema  $R$ .  
 The SQL expression  
 Select \*  
 From  $r_1$   
 Where  $(A,B,C)$  in (select \* from  $r_2$ )  
 Is equivalent to:

1.  $r_1 - r_2$
2.  $r_1 \cap r_2$
3.  $r_1 \cup r_2$
4.  $r_2 - r_1$

## ELECTRICAL SCIENCE

56. The current and voltage sources shown in figure are ideal. The power delivered by the 2A current source is

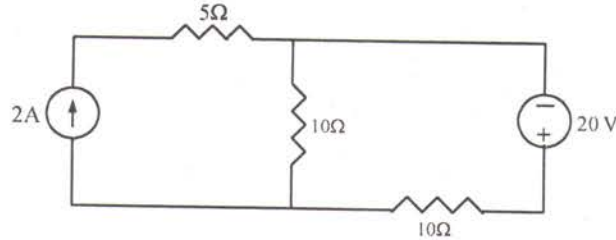

1. 0 W      2. 10 W      3. 20 W      4. 40 W
57. Consider a unity negative feedback system having open loop transfer function

$$G(s) = \frac{K(s^2 - 2s + 2)}{(s+1)(s+2)(s+3)}$$

where  $K > 0$ . The root locus for the system intersects the imaginary axis at the points

1.  $j1.0, -j1.0$       2.  $j1.2, -j1.2$   
 3.  $j2.2, -j2.2$       4.  $j4.6, -j4.6$
58. A 3 phase 11 kV, 50 Hz generator feeds a load of 50 MW at unity power factor through a short transmission line of reactance 0.2 pu with respect to base of 100 MVA, 11 kV. Neglecting line resistance, the amount of reactive power in MVAR injected at the load end to keep the load end voltage at 11 kV is
1. -2.506      2. 0      3. 2.506      4. 25.06

59. Consider the bridge rectifier with source inductance  $L_s$  as shown in figure. Assuming that the load current  $I_d$  is smooth and ripple free, the dc output voltage ( $V_d$ ) of the rectifier is

1.  $\frac{V_m}{\pi} \left( 1 - \frac{\omega L_s}{V_m} I_d \right)$       2.  $\frac{2V_m}{\pi} \left( 1 - \frac{\omega L_s}{V_m} I_d \right)$   
 3.  $\frac{V_m}{\pi} \left( 1 - \frac{\omega L_s}{2V_m} I_d \right)$       4.  $\frac{2V_m}{\pi} \left( 1 - \frac{\omega L_s}{2V_m} I_d \right)$

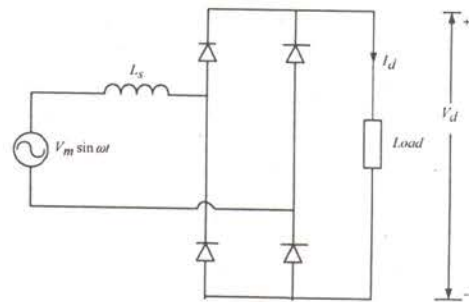

60. In the figure, the voltage across the inductor is 25 V. Then peak value ( $V_m$ ) of supply voltage is

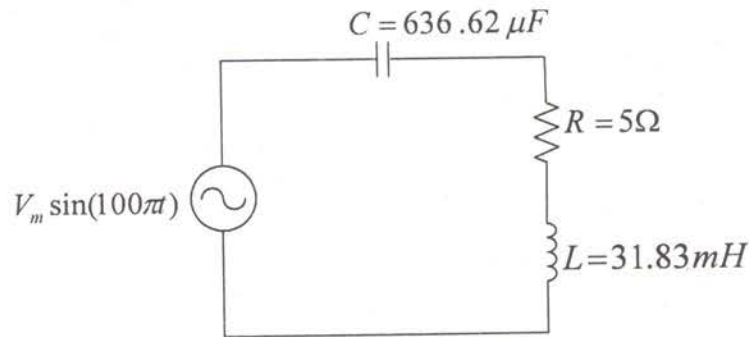

1. 8.84V      2. 12.5V      3. 17.68V      4. 25V
61. Consider a unity negative feedback system having open loop transfer function  $G(s) = \frac{8}{s(s+1)(2s+1)}$ . The number of clockwise encirclements of  $-1+j0$  point by the Nyquist plot of the above system is
1. 0      2. 1      3. 2      4. 3
62. A 10 MVA, 6.6 kV generator has following sequence reactances  $X_1 = X_2 = 0.2$  pu and  $X_0 = 0.05$  pu. A L-L fault occurs between phase b and c of the generator running at no load and at rated voltage. The voltage in the healthy phase in kV is
1. 0      2. 1.904      3. 3.81      4. 6.6
63. A load of  $11\Omega$  is connected to two 1-phase ideal transformers  $T_1$  and  $T_2$  as shown in figure. The input power to the primary is

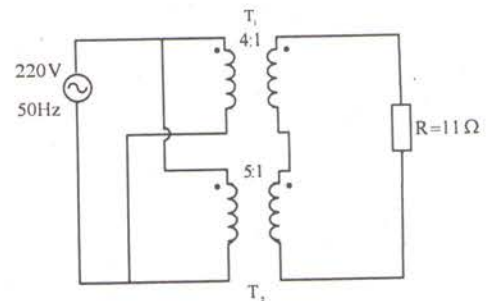

1. 54 W      2. 891 W      3. 1100 W      4. 1500 W
64. A 3 phase transmission line has flat horizontal spacing of 2 m between adjacent conductors. The radius of each conductor is 0.5 cm. At certain instant, the charges on the center conductor and on one of the outside conductors are identical and the voltage drop between these identically charged conductors is 600 V. Neglecting the effect of ground, the value of the identical charge in  $\mu C/km$  at the instant specified is
1. 11.34      2. 13.90      3. 24.08      4. 30.10

65. A 220 V DC shunt motor has an armature circuit resistance of  $0.2 \Omega$  and field resistance of  $110 \Omega$ . At no load, the motor takes 5 A and runs at 1500 rpm. The rotational losses at no load and full load are the same. If the motor draws 52 A at rated voltage and rated load, neglecting armature reaction, approximate value of the motor speed in rpm is

1. 1400      2. 1436      3. 1470      4. 1500

MATERIALS SCIENCE

66. Figure (a) shows a reversible cell containing zinc and platinum electrodes which are short-circuited whereas figure (b) shows a zinc metal immersed in a hydrogen saturated acid solution.

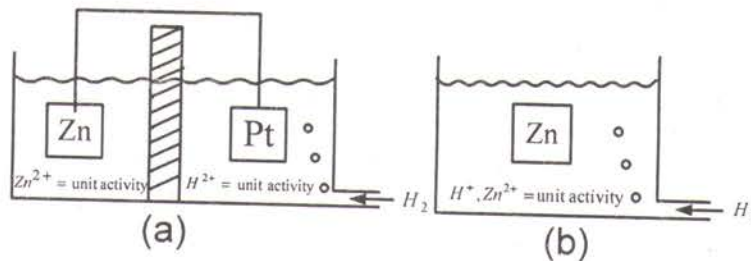

Given: Standard oxidation-reduction (redox) potentials for  $Zn = Zn^{2+} + 2e$  is  $-0.763 \text{ V}$ , for  $H_2 = 2H^+ + 2e$  is  $0 \text{ V}$  and for  $Pt = Pt^{2+} + 2e$  is  $1.2 \text{ V}$ .

Choose the appropriate phenomenon that would occur:

- Zinc dissolution will be faster in case of (a) as voltage difference between anode and cathode is more (than (b)).
  - Short circuiting causes no potential difference between Pt and Zn in (a) and hence dissolution will not occur in (a), whereas dissolution in (b) occurs.
  - No dissolution occurs in either situation as there is no potential difference between cathode and anode in (a), and for (b), there is no cell formation (only one electrode).
  - In both cases, rate of zinc dissolution be same. Pt act as equilibrium hydrogen electrode in (a) whereas Zn-metal will act as both cathode and anode (localized).
67. The critical resolved shear stress of a metal is  $2.0 \text{ MPa}$ . During plastic deformation of a single crystal of this metal, the slip plane rotates in a manner so that the angle between the tensile axis and the slip direction changes from  $45^\circ$  to  $30^\circ$ . If the angle between the normal to the slip plane and the tensile axis remains unaltered at  $60^\circ$ , the tensile stress changes as follows:
- Increased by  $1.04 \text{ MPa}$
  - Decreased by  $1.04 \text{ MPa}$
  - Increased by  $0.16 \text{ MPa}$
  - Decreased by  $0.16 \text{ MPa}$
68. In a super conducting wire-loop, the current flow decays following the equation  $i_t = i_0 \cdot \exp\left[-\frac{R}{L}t\right]$  where, R and L represent resistance and self inductance, respectively. The self-inductance of half a meter super conductor wire-loop having wire diameter of  $1.2$

mm is found to be  $2 \times 10^{-6} \Omega \cdot s$ . The maximum resistance that this superconductor loop should possess to maintain a current flow of 1A for 1 year with 2% decay will be:

1.  $4.04 \times 10^{-8} \Omega$
2.  $3.07 \times 10^{-14} \Omega$
3.  $1.28 \times 10^{-15} \Omega$
4.  $2.48 \times 10^{-13} \Omega$

69. The atomic weight and density of iron are 55.85 g/mol and  $7.86 \text{ g/cm}^3$ , respectively. If net magnetic moment per atom of iron is 2.22 Bohr magneton, the saturation magnetization for iron will be:

[Given: Avogadro's no:  $6.023 \times 10^{23}$  atoms/mol and Bohr magneton:  $9.27 \times 10^{-24} \text{ A}\cdot\text{m}^2$ ]

1.  $1.52 \times 10^6 \text{ A/m}$
2.  $1.73 \times 10^6 \text{ A/m}$
3.  $1.91 \times 10^6 \text{ A/m}$
4.  $2.03 \times 10^6 \text{ A/m}$

70. The flux of carbon atoms during its steady state diffusion while carbonizing a steel plate on one side and decarburizing it on the other side is  $2 \times 10^{-10} \text{ g/cm}^2\cdot\text{s}$ . The diffusion co-efficient of carbon in steel at the carburizing temperature is  $2.8 \times 10^{-11} \text{ m}^2/\text{s}$ . If the concentration of carbon at a depth of 10 mm beneath the carburizing surface is  $0.75 \text{ kg/m}^3$ , the concentration of carbon at a depth of 2 mm from the surface is closest to:

1.  $0.80 \text{ kg/m}^3$
2.  $1.20 \text{ kg/m}^3$
3.  $1.32 \text{ kg/m}^3$
4.  $2.10 \text{ kg/m}^3$

71. Silicon carbide has zinc blende structure. The atomic radii for silicon and carbon are 0.118 and 0.071 nm, respectively. The atomic weights of Si and C are 28.09 and 12.01, respectively. The atomic packing factor and the density of SiC are:

1. 0.40 and  $3.21 \text{ g/cm}^3$
2. 0.62 and  $2.24 \text{ g/cm}^3$
3. 0.28 and  $2.24 \text{ g/cm}^3$
4. 0.31 and  $3.21 \text{ g/cm}^3$

72. The cooling curve of a Pb-Sn alloy shows that the first solid nucleates at  $250^\circ\text{C}$ . The isothermal line at  $250^\circ\text{C}$  touches the liquidus line corresponding to Sn content of 30 wt%. The amount of the solid phase which is formed prior to eutectic reaction is closest to:

1.  $f_\alpha = 25\%$
2.  $f_\alpha = 75\%$
3.  $f_\alpha = 10\%$
4.  $f_\alpha = 5\%$

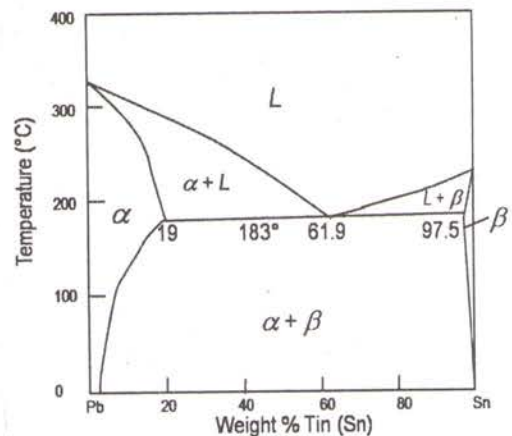

73. The elastic moduli of Al and SiC fibers are 69.0 GPa and 406.0 GPa, respectively, and the corresponding densities are  $2.70 \text{ Mg/m}^3$  and  $3.05 \text{ Mg/m}^3$ , respectively. The specific modulus for an Al-matrix with 20 vol% of aligned continuous SiC fiber is:
1.  $10.1 \text{ GPa/Mg/m}^3$
  2.  $3.4 \text{ GPa/Mg/m}^3$
  3.  $49.2 \text{ GPa/Mg/m}^3$
  4.  $84.4 \text{ GPa/Mg/m}^3$
74. At 300K calculate the density of conduction electrons in a silicon wafer doped with  $2 \times 10^{16}/\text{cm}^3$  of Boron. (Intrinsic carrier density of Si at 300K is  $9.65 \times 10^9/\text{cm}^3$ )
1.  $5 \times 10^3/\text{cm}^3$
  2.  $10^{10}/\text{cm}^3$
  3.  $2 \times 10^{12}/\text{cm}^3$
  4.  $10^{20}/\text{cm}^3$
75. 5 g of a powder (with apparent density of  $4.3 \text{ g/cm}^3$ ) is fed into a compaction die having 10 mm diameter. The powder is then compacted to a green density of  $6.6 \text{ g/cm}^3$  using an uniaxial single action press (pressing by upper punch only). Assuming no mass loss and neglecting elastic spring back effect during compaction, the upper punch will travel by a height of:
1. 5.16 mm
  2. 9.65 mm
  3. 14.81 mm
  4. 15.35 mm

### FLUID MECHANICS

76. Two reservoirs that differ by a surface elevation of 40 m, are connected by a commercial steel pipe of diameter 8 cm. If the desired flow rate is 200 N/s of water at  $20^\circ\text{C}$ , determine the length of the pipe. Assume fluid properties of water at  $20^\circ\text{C}$  as  $\rho=1000 \text{ kg/m}^3$  and  $\mu=0.001 \text{ kg/m-s}$ . The value of friction factor ( $f$ ) = 0.0185 may be chosen if required.
1. 20.5 m
  2. 205 m
  3. 2050 m
  4. 20500 m
77. A vane, with turning angle of  $\theta$ , is attached to a cart. The cart and vane, of mass  $M$ , roll on a level track, with a speed of  $u$  along  $x$ -axis as shown in the figure. Friction and air resistance may be neglected. The vane receives a jet of water (density  $\rho$ ) which leaves horizontally at a uniform speed of  $V$ . The nozzle exit area is  $A$ . The governing differential equation describing the velocity of the cart as a function of time is,



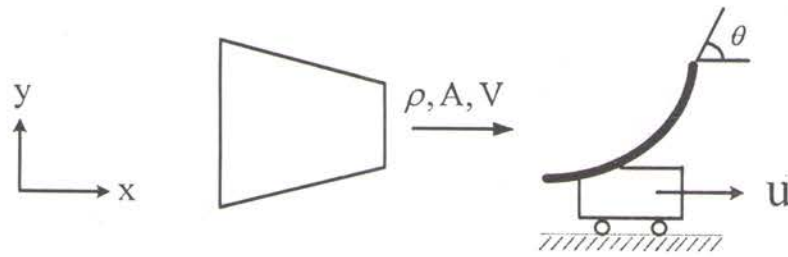

1.  $M \frac{du}{dt} = \rho(V - u)^2 A \cos\theta$
2.  $M \frac{du}{dt} = \rho(V^2 - u^2) A (1 - \cos\theta)$
3.  $M \frac{du}{dt} = \rho(V^2 - u^2) A \cos\theta$
4.  $M \frac{du}{dt} = \rho(V - u)^2 A (1 - \cos\theta)$

78. A liquid of specific weight  $9 \text{ kN/m}^3$  flows by gravity through a  $0.3 \text{ m}$  tank and a  $0.3 \text{ m}$  capillary tube at a rate of  $1.13 \times 10^{-6} \text{ m}^3/\text{s}$ , as shown in the figure. Top of the tank and outlet of the capillary are open to the atmosphere. If the flow is laminar, fully developed and incompressible, then the viscosity of the liquid, neglecting entrance effect, is numerically closest to

1.  $1.86 \times 10^{-4} \text{ Pa}\cdot\text{s}$
2.  $3.38 \times 10^{-4} \text{ Pa}\cdot\text{s}$
3.  $6.75 \times 10^{-4} \text{ Pa}\cdot\text{s}$
4.  $7.43 \times 10^{-4} \text{ Pa}\cdot\text{s}$

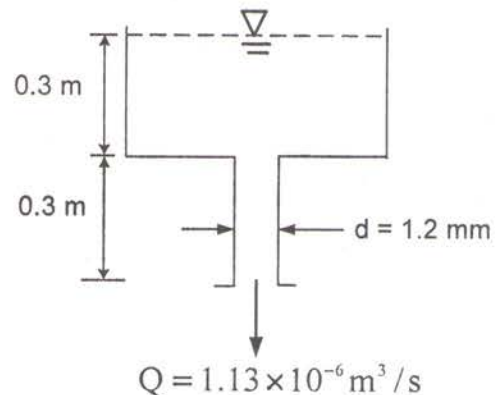

79. A fluid is flowing down a vertical tube (dia =  $6 \text{ mm}$ ) due to gravity ( $g = 9.81 \text{ m/s}^2$ ) only. The density and viscosity of the liquid are  $900 \text{ kg/m}^3$  and  $0.01 \text{ Pa}\cdot\text{s}$ , respectively. Assume the flow to be incompressible, laminar and fully developed. If the length of the tube is  $2 \text{ m}$ , then neglecting all minor losses, the volumetric flow rate, in  $\text{m}^3/\text{h}$ , is numerically closest to

1. 0.1
2. 0.4
3. 0.2
4. 0.8

80. A homogenous right circular cylinder of length  $L$ , radius  $R$  and specific gravity  $SG$  is floating in water with its axis vertical. If  $SG = 0.8$ , then the minimum value of  $R/L$  above which the body will always be stable is

1. 0.16
2. 0.36
3. 0.56
4. cannot predict due to insufficient data

81. Water (density =  $1000 \text{ kg/m}^3$ ) flows steadily through the box as shown in the figure. Assume all ducts to be circular, and all velocity profiles to be uniform. If the inflow velocity is  $2 \text{ m/s}$ , then the overall magnitude of force required to hold the box stationary against the flow momentum is numerically closest to

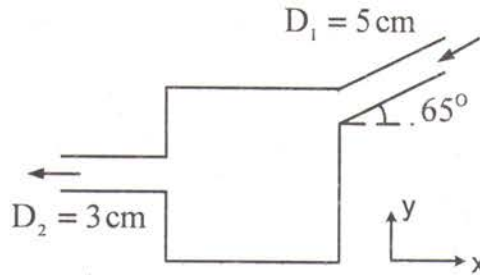

1. 10 N                      2. 15 N                      3. 20 N                      4. 25 N
82. Consider a cone-plate viscometer arrangement as shown in the figure. The angle of the cone is very small ( $\theta = 10^\circ$ ) and the gap is filled with a test liquid. A torque of  $M = 0.001 \text{ N}\cdot\text{m}$  is being applied to rotate the cone having  $R = 0.01 \text{ m}$  at a constant rate of  $\Omega = 100 \text{ s}^{-1}$ . Assuming a linear velocity profile in the liquid, the viscosity of the test liquid is numerically closest to

1. 0.6  
2. 0.7  
3. 0.8  
4. 0.9

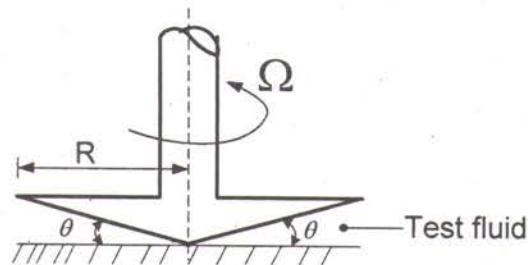

83. Steady, fully developed flow takes place between two infinitely wide parallel plates. Density of the fluid is assumed to be constant. The top plate and bottom plate both move towards the right with a velocity  $u_1$ , as depicted in the figure. Assuming zero pressure gradient, the fully developed velocity profile between the plates is given by,

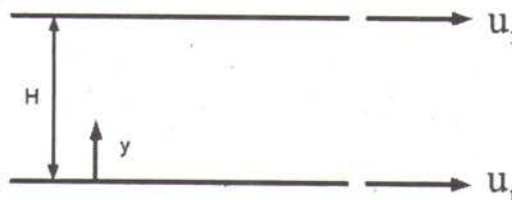

1.  $u = u_1$                       2.  $u = 0$                       3.  $u = u_1 \frac{y}{H}$                       4.  $u = u_1 \left(1 - \frac{y}{H}\right)$

84. Air (density =  $1.2 \text{ kg/m}^3$ ) is entering the bottom of an  $85^\circ$  conical flow meter circular duct at a mass flow rate of  $0.3 \text{ kg/s}$  as shown in the figure. This flow supports a centered conical body by steady annular flow around the cone and exits at same velocity as it enters. The weight of the body, in Newton, is numerically closest to

1. 2.5
2. 4.5
3. 6.5
4. 8.5

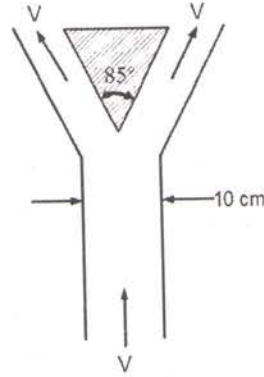

85. A tank of volume  $\nabla$  contains a gas at pressure  $p$  (absolute) and temperature  $T$ , with a uniform state. At  $t=0$ , the gas begins escaping from the tank through a valve with a flow area of  $A$ . The air passing through the valve has an average speed of  $\bar{V}$  and density  $\rho$ . If the universal gas constant is  $R$ , then what is the instantaneous rate of change of density in the tank at  $t=0$ ?

1. 0
2.  $\frac{\rho A \bar{V}}{\nabla}$
3.  $-\frac{\rho A \bar{V}}{\nabla}$
4.  $\frac{-\partial p}{RT}$

### SOLID MECHANICS

86. Find the magnitude of total deflection at  $B$ . (Assume elastic modulus =  $1 \text{ unit}$ , moment of inertia =  $1 \text{ unit}$ , area of cross-section =  $2 \text{ units}$  and length =  $L = 1 \text{ unit}$ )

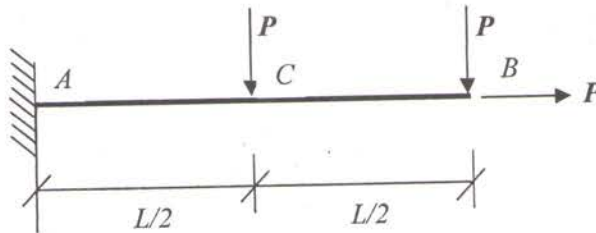

1.  $\frac{7P}{16}$
2.  $\frac{7P}{8}$
3.  $\frac{P\sqrt{53}}{16}$
4.  $\frac{P\sqrt{113}}{16}$

87. A dumbbell-shaped pressure vessel of uniform wall thickness  $t$  is subjected to an internal pressure  $p$ . The ends are made of spherical shaped vessels of diameter  $d$ , connected by a cylindrical vessel of diameter  $d$  at the middle as shown. Find the longitudinal stress,  $\sigma_l$  at the center of the cylindrical portion of the dumbbell-shaped pressure vessel.

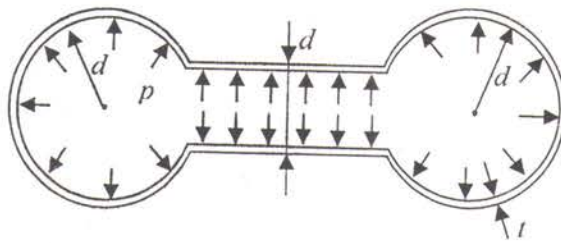

1.  $\sigma_l = \frac{2pd}{t}$       2.  $\sigma_l = \frac{pd}{t}$       3.  $\sigma_l = \frac{pd}{2t}$       4.  $\sigma_l = \frac{pd}{4t}$

88. A cubical block is subjected to a stress state given by:

$$\begin{pmatrix} 4\sigma & 0 & 44 \\ 0 & 2\sigma & -34 \\ 44 & -34 & -\sigma \end{pmatrix} \text{ MPa}$$

What is the magnitude of  $\sigma$  for which the factor of safety against yield is about 2. Use von Mises criterion for yield. The yield strength of the material may be taken to be 520 MPa.

1. 36 MPa      2. 55 MPa      3. 117 MPa      4. 81 MPa

89.  $AB$  is a thin hollow tube of mean diameter  $d$  and thickness  $t$ . The tube is fixed to cables and pulled at  $D$  as shown. Find the load  $P$  for which the tube is likely to buckle according to Euler's formula.

1.  $\frac{\pi^3 Ed^3 t}{4L^2(\sqrt{3}+1)}$       2.  $\frac{\pi^2 Ed^3 t}{L^2(\sqrt{3}+1)}$
3.  $\frac{\pi^3 Ed^3 t}{4L^2(\sqrt{3}-1)}$       4.  $\frac{\pi^2 Ed^3 t}{L^2(\sqrt{3}-1)}$

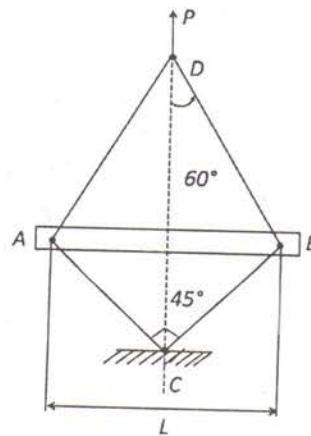

90. A force  $F$  is acting at the joint  $B$  of the truss  $BCD$  shown. Find the total strain energy stored in the elastic system due to the force  $F$ . Assume elastic modulus of  $E$  for all the bars.

1.  $\frac{F^2 L}{AE} \left[ \frac{1}{\sqrt{2}} + \frac{3}{8} \right]$     2.  $\frac{F^2 L}{AE} \left[ \sqrt{2} + \frac{3}{4} \right]$   
 3.  $\frac{F^2 L}{AE} \left[ 2\sqrt{2} + \frac{3}{4} \right]$     4.  $\frac{F^2 L}{AE} \left[ \sqrt{2} + \frac{3}{8} \right]$

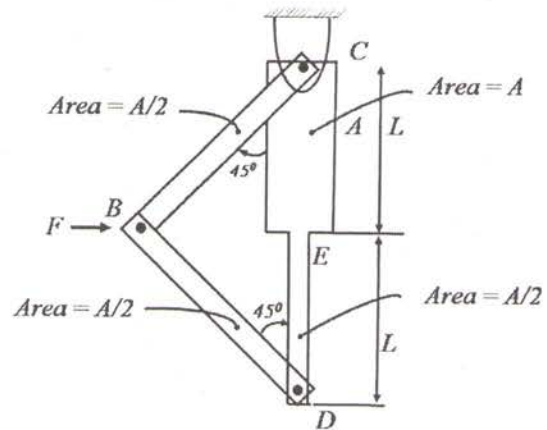

91. A stepped bar is hung from the ceiling as shown in the figure. The cross-section of  $AB = 500 \text{ mm}^2$ , and that of  $BC = 200 \text{ mm}^2$ . Assuming that the density of both the rods are the same and equal to  $7500 \text{ kg/m}^3$ , find the axial force at a section  $a-a'$  just above  $B$ . Take  $g = 10 \text{ m/s}^2$ . A downward force of  $20 \text{ N}$  is acting at  $B$  and a force of  $5 \text{ N}$  at  $C$  is acting upwards.

1.  $32.5 \text{ N}$   
 2.  $22.5 \text{ N}$   
 3.  $90 \text{ N}$   
 4.  $100 \text{ N}$

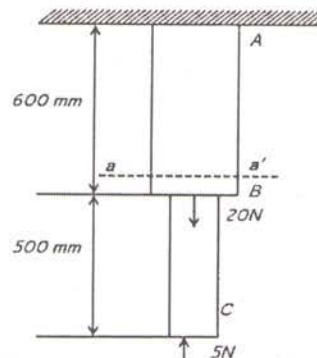

92. Select the appropriate pair of elements with the same state of stress as given by the following Mohr's circles.

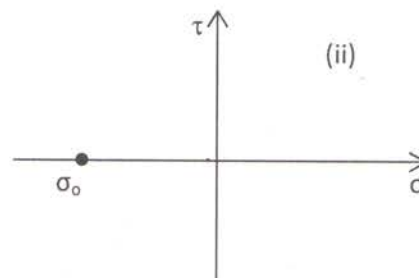
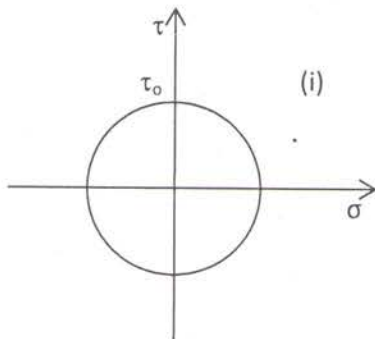

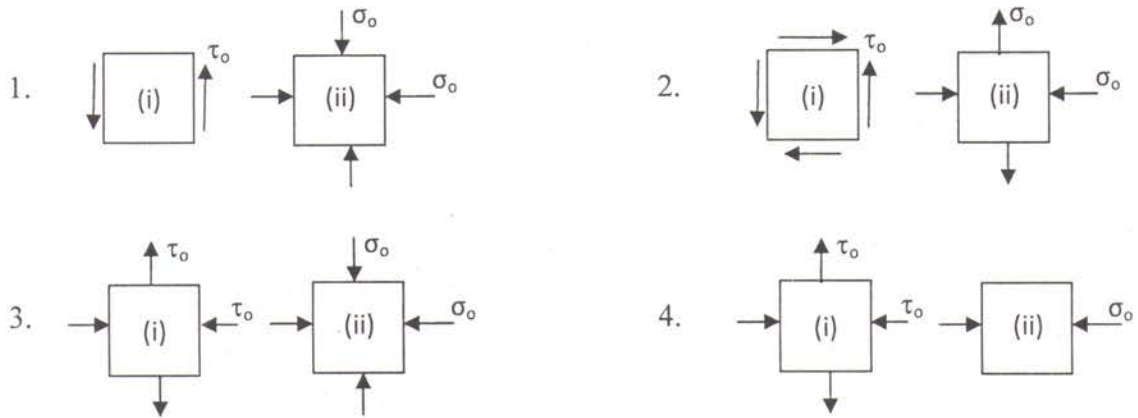

93. A strip of length,  $L$ , breadth,  $b$ , and height,  $h$ , is initially pulled with a force  $P$  and held while another strip B of the same dimension is taken and pasted to the strip A in the pulled condition as shown in the figure. Once the bond between A and B is fully developed, the force  $P$  is removed from A. Find the amount of shear force transferred to strip A by B at the interface.

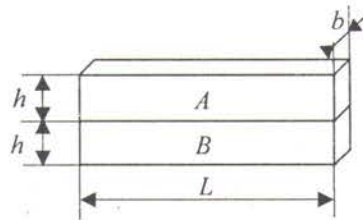

1.  $\frac{PL}{4}$       2.  $\frac{PhL}{8}$       3.  $\frac{PL}{8}$       4.  $\frac{Ph^2}{4}$

94. A rubber band of unstretched length equal to  $2r_0$  is forced down the frustum of a cone as shown. Determine the average extensional strain in the band as a function of the distance from the top of the frustum,  $z$ .

1.  $\frac{\pi(h+z)}{h} - 1$   
 2.  $\frac{\pi z}{h}$   
 3.  $\frac{z}{h}$   
 4.  $\frac{z}{hr_0}$

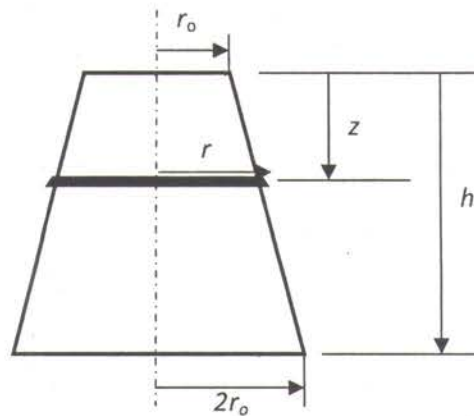

95. A sign supported by a post of circular cross-section is subjected to a uniform wind load that acts normal to its plane as shown in the figure. What are the magnitudes of the normal and shear components of stress ( $\sigma_{xx}, \tau_{xy}$ ) at A? Assume the moment of inertia ( $I$ ) =  $5 \times 10^{-6} \text{ m}^4$ .

1.  $\sigma_{xx} = 90 \text{ MPa}, \tau_{xy} = 30 \text{ MPa}$
2.  $\sigma_{xx} = 180 \text{ MPa}, \tau_{xy} = 30 \text{ MPa}$
3.  $\sigma_{xx} = 90 \text{ MPa}, \tau_{xy} = 15 \text{ MPa}$
4.  $\sigma_{xx} = 180 \text{ MPa}, \tau_{xy} = 15 \text{ MPa}$

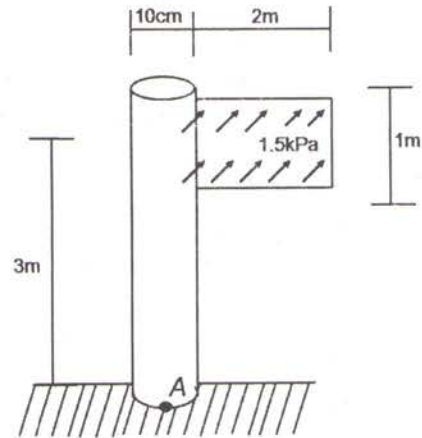

### THERMODYNAMICS

96. Moist air enters a dehumidifier at  $30^\circ\text{C}$  with an absolute humidity of  $0.0211 \text{ kg moisture/kg dry air}$ . The enthalpy of saturated vapour at this temperature is  $2556.25 \text{ kJ/kg}$ . The moist air leaves the humidifier with an absolute humidity of  $0.0107 \text{ kg moisture/kg dry air}$  and  $15^\circ\text{C}$ . At this temperature, the enthalpies of saturated liquid and vapour are  $62.98 \text{ kJ/kg}$  and  $2528.91 \text{ kJ/kg}$  respectively. Given,  $c_{p,\text{air}} = 1.005 \text{ kJ/kgK}$ . The heat removed ( $\text{kJ/kg}$  of dry air) is
1. 35.4
  2. 41.3
  3. 47.9
  4. 49.7
97. A refrigerator works on an ideal vapour compression refrigeration cycle operating between  $0.16 \text{ MPa}$  and  $0.80 \text{ MPa}$ . The heat rejection to the environment is  $180 \text{ kJ/kg}$ . Saturation property of the refrigerant is given as:

| Pressure, MPa | Enthalpy, kJ/kg  |                  |
|---------------|------------------|------------------|
|               | Saturated Liquid | Saturated vapour |
| 0.16          | 31               | 240              |
| 0.80          | 95               | 267              |

The work input ( $\text{kJ/kg}$ ) to the compressor is

1. 8
2. 27
3. 35
4. 64

98. Consider a steady-flow Carnot vapour power cycle within the saturation dome with the heat addition process between the saturated liquid and saturated vapour points. The cycle operates between 10 MPa and 0.02 MPa. Heat rejected in the condenser is 850 kJ/kg. Saturation properties of the working fluid:

| Pressure, MPa | Temperature, °C | Specific entropy (kJ/kgK) |                  |
|---------------|-----------------|---------------------------|------------------|
|               |                 | Saturated liquid          | Saturated vapour |
| 10            | 311             | 3.36                      | 5.62             |
| 0.02          | -               | 0.83                      | 7.91             |

The thermal efficiency of the cycle is

1. 35.6%                      2. 46.6%                      3. 64.4%                      4. 84.6%
99. An ideal regenerative Rankine cycle employs one open feed water heater (FWH) which operates at 1.2 MPa. The extracted steam leaves the turbine at 220°C. The condensate enters the FWH at an enthalpy of 195 kJ/kg.  
Water property data:  $h=2862$  kJ/kg at 1.2 MPa and 220°C. Saturated liquid enthalpy at 1.2 MPa = 800 kJ/kg.  
Neglecting pump work input, the mass flow fraction extracted from the turbine is
1. 0.127                      2. 0.227                      3. 0.327                      4. 0.427
100. A container having a volume of  $0.5 \text{ m}^3$  is initially filled with saturated water at 250°C. Water is withdrawn from the container through a pipe such that the final mass in the container is half of the initial mass. Throughout this process, temperature of water is maintained constant by transferring heat to water. Specific volume and internal energy of saturated water at 250°C are  $0.001251 \text{ m}^3/\text{kg}$  and 1080 kJ/kg respectively. The internal energy of water at the end of the process is 1119 kJ/kg. The enthalpy of saturated liquid at 250°C is 1085 kJ/kg. The heat transfer in kJ is
1. 5875                      2. 8780                      3. 10680                      4. 12395
101. In an ideal air standard Otto Cycle, the pressure and temperature at the beginning of compression are 101 kPa and 27°C respectively. The ratio of stroke volume to clearance volume is 9. Heat added to the cycle is 1800 kJ/kg.  
Given,  $\gamma_{\text{air}}=1.4$  and  $c_{v,\text{air}} = 0.718$  kJ/kgK. Maximum temperature (°C) in the cycle is
1. 2475                      2. 2723                      3. 2987                      4. 3300
102. A house is being heated during winter by a well known brand heat pump. The ambient temperature is  $-10^\circ\text{C}$  and the house is maintained at  $25^\circ\text{C}$ . The house loses heat at a rate of 30 kW. The power input to the heat pump is 5 kW. The coefficient of performance of the heat pump is
1. 1.0                      2. 3.0                      3. 6.0                      4. 7.5



103. An insulated box is divided into two equal compartments by a rigid partition. One compartment contains 1 kmol of  $N_2$  whereas the other compartment contains 1 kmol of  $O_2$ . Pressure and temperature at both the compartments are 101 kPa and  $200^\circ\text{C}$ . The partition is removed and the gases are allowed to mix to come to a thermodynamic equilibrium state. The universal gas constant is  $8.314 \text{ kJ/kmolK}$ . The change in entropy ( $\text{kJ/kmolK}$ ) is
1. 6.6                      2. 8.5                      3. 11.5                      4. 15.3
104. In an air-standard Brayton Cycle with regenerator, air enters a single-stage compressor at 100 kPa,  $20^\circ\text{C}$  and leaves the compressor at 1 MPa. The maximum temperature in the cycle is  $1200^\circ\text{C}$ . The regenerator effectiveness is 0.8. For air,  $\gamma_{\text{air}}=1.4$  and  $c_{p,\text{air}} = 1.005 \text{ kJ/kgK}$ . The efficiency of the cycle is
1. 46.7%                      2. 49.2%                      3. 53.4%                      4. 58.3%
105. Air gets preheated in a constant pressure heat exchanger where air enters at  $40^\circ\text{C}$  with a mass flow rate of 10 kg/s. The air exits the pre-heater at  $100^\circ\text{C}$ . Consider air as an ideal gas with  $c_p = 1.005 \text{ kJ/kgK}$  and  $c_v = 0.718 \text{ kJ/kgK}$ ; ambient temperature is  $27^\circ\text{C}$ . The change in energy (kJ) of the air stream in the pre-heater is
1. -74                      2. -53                      3. 53                      4. 74

ELECTRONICS

106.

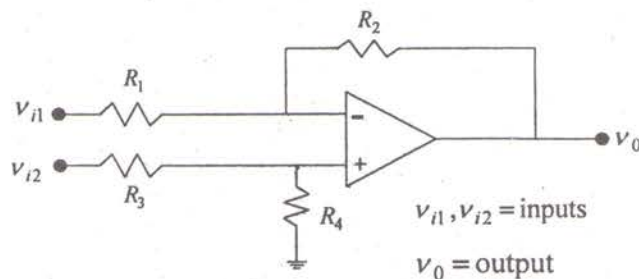

For this OPAMP-based difference amplifier circuit, determine the common-mode rejection ratio (CMRR) in dB. Assume  $\frac{R_2}{R_1} = 15$  and  $\frac{R_4}{R_3} = 16$ .

1. 86.77 dB                      2. 48.15 dB                      3. 68.34 dB                      4. 102.28 dB

107. The minimized form of the logic expression  $f(A, B, C, D) = \Pi(0, 3, 4, 5, 6, 7, 11, 13, 14, 15)$  is

1.  $(\bar{A} + \bar{C} + \bar{D})(B + D)(B + C)(C + D)$
2.  $\bar{A}\bar{C}\bar{D} + BD + BC + CD$
3.  $(A + C + D)(\bar{B} + \bar{D})(\bar{B} + \bar{C})(\bar{C} + \bar{D})$
4.  $ACD + \bar{B}\bar{D} + \bar{B}\bar{C} + \bar{C}\bar{D}$

108. A 8 kHz communication channel has an SNR of 30 dB. If the channel band width is doubled keeping the signal power constant, the SNR of the modified channel will be

1. 27 dB
2. 30 dB
3. 33 dB
4. 60 dB

109. A voice signal band limited to 3.4 kHz is sampled at 8 kHz. It is then pulse-code modulated using 64 quantization levels. Ten such signals are time-division multiplexed (TDM) using one 5-bit synchronizing word for every alternate frame. The minimum channel bandwidth required for transmission of the TDM signal is

1. 260 kHz
2. 240 kHz
3. 44 kHz
4. 24 kHz

110. Base-2 representation of decimal number 157.96875 is

1. 001101111.11111
2. 10011101.11111
3. 001101111.11101
4. 10011101.11101

111. Let  $s(t)$  be the step response of a linear system. Then the response of this system to an input  $u(t)$  is given by

1.  $\int_{-\infty}^{\infty} s(t - \tau)u(\tau)d\tau$
2.  $\frac{d}{dt} \int_{-\infty}^{\infty} s(t - \tau)u(\tau)d\tau$
3.  $\int_{-\infty}^{\infty} s(t - \tau) \left[ \int_{-\infty}^{\infty} s(t - \tau) \left[ \int_{-\infty}^{\infty} u(\tau_1)d\tau_1 \right] d\tau \right] d\tau$
4.  $\int_{-\infty}^{\infty} [s(t - \tau)]^2 u(\tau)d\tau$

112.

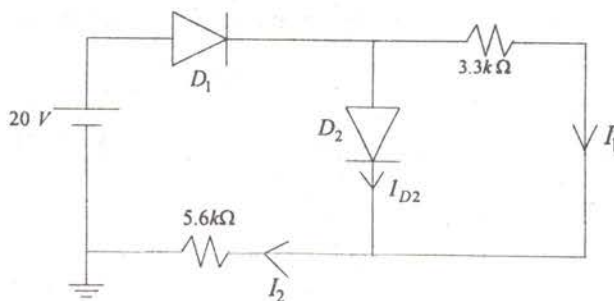

For the circuit shown, determine the currents  $I_1$ ,  $I_2$  and  $I_{D2}$ . The cut-in voltage of each diode is 0.7 V.

- |                                     |                                     |
|-------------------------------------|-------------------------------------|
| 1. 0.104 mA, 2.128 mA, and 2.024 mA | 2. 0.310 mA, 4.213 mA, and 3.903 mA |
| 3. 0.212 mA, 3.321 mA, and 3.109 mA | 4. 0.175 mA, 2.918 mA, and 2.743 mA |

113. For the circuit shown, what will be the output voltage ( $V_O$ ) and collector-emitter voltage ( $V_{CE}$ )? The transistor parameters are:  $V_{BE(on)}=0.7$  V, and  $\beta=100$ .

1. 2.3 V and 2.9 V
2. 4.22 V and 5.35 V
3. 1.4 V and 3.05 V
4. 3.91 V and 4.69 V

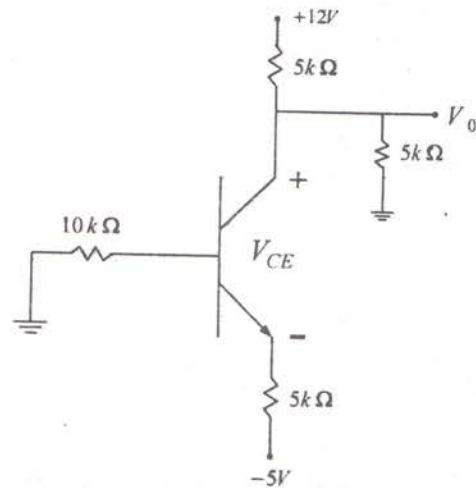

114. A logic circuit has the following logical inputs and output:

Inputs: A, B, C

Output: Y

The output is high only when a majority of the inputs is high. Which one of the following is the correct logical relation between inputs and output?

- |                       |                 |
|-----------------------|-----------------|
| 1. $Y = BC + AC + AB$ | 2. $Y = A + BC$ |
| 3. $Y = ABC$          | 4. $Y = AB + C$ |

115. Let  $x(n)$  and  $y(n)$  represent the input and output of an LTI system having an impulse response  $h(n) = x(n-1) * y(n)$ , where '\*' denotes the discrete-time convolution operation. If  $X(z)$  and  $Y(z)$  are given as  $1 - 3z^{-1}$  and  $1 + 2z^{-2}$ , respectively, then the output of the system for the input  $\delta(n-1)$

1. has Z-transform  $z^{-1}X(z)Y(z)$
2. has z-transform  $1 - 3z^{-1} + 2z^{-2} - 6z^{-3}$
3. is equal to  $\delta(n-2) - 3\delta(n-3) + 2\delta(n-4) - 6\delta(n-5)$
4. is equal to  $\delta(n+2) + 3\delta(n-3) - 2\delta(n-4) + 6\delta(n+5)$

FOR ROUGH WORK

---